

Finsa Process

Finsa Process



1

Modules

Pro
Max

2

Worktops

Fintop +
Fintop Xtrim
Fintop SQ

3

Fronts

Finporta

Modules

Pro

Professional series of kitchen modules that offer a wide variety of sizes, options and items that allow you to fit it into any project

Main features

Baseboard

Fimoplast Moisture Resistant 16 mm, with a double-sided design and finish

Edge

Front section in 1 mm PVC, others in 0.4 mm PVC

Back

Fimoplast Standard 6 mm, White on both sides or design/kraft

Assembly

Allen assembly screw + Wooden peg

Packaging

Shrink wrap with MR identification

Technical specifications

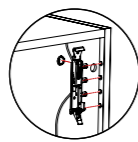

Machining for MRden hanger
*Hangers not included

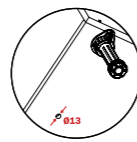

Suitable for 40/50 mm fin
* Legs not included

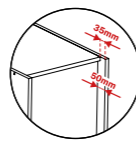

Rear recess with space for sockets, pipes and ventilation

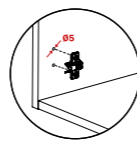

Ø5 mm holes for hinges

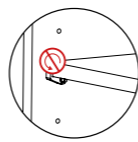

Anti-roll Rack holder



More information

Manufactured on a 16 mm Fimoplast Moisture Resistant baseboard, it has excellence performance in humid environments. This quality of board offers an advantage in terms of hardware anchorage and flex. The melamine coating allows easy cleaning, is scratch resistant and has an antibacterial surface.



Moisture resistant



E05



Anti-bacterial



Good fastener performance



Machined



Bending resistance

Designs

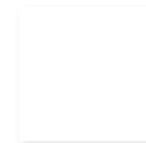

Blanco Medio
Soft III



Aluminio
Soft III

Pro range module diagram

Module diagram with low H70

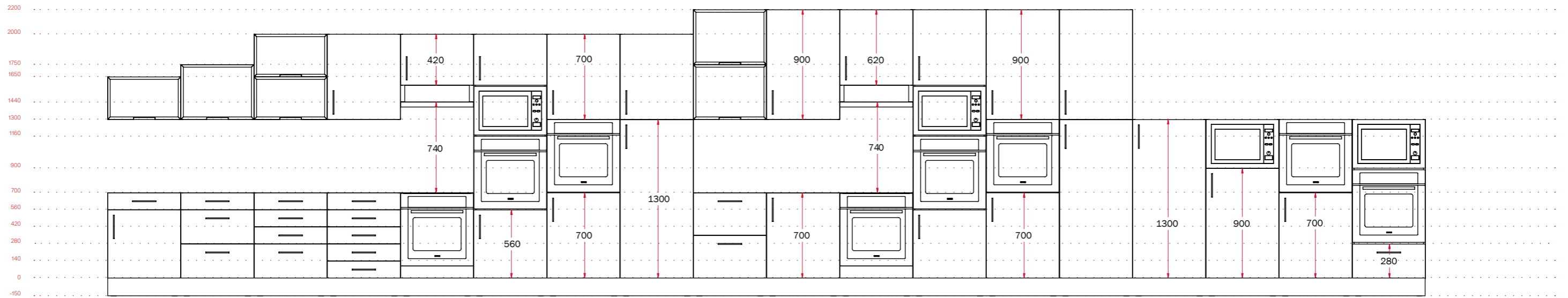

Module diagram with low H80

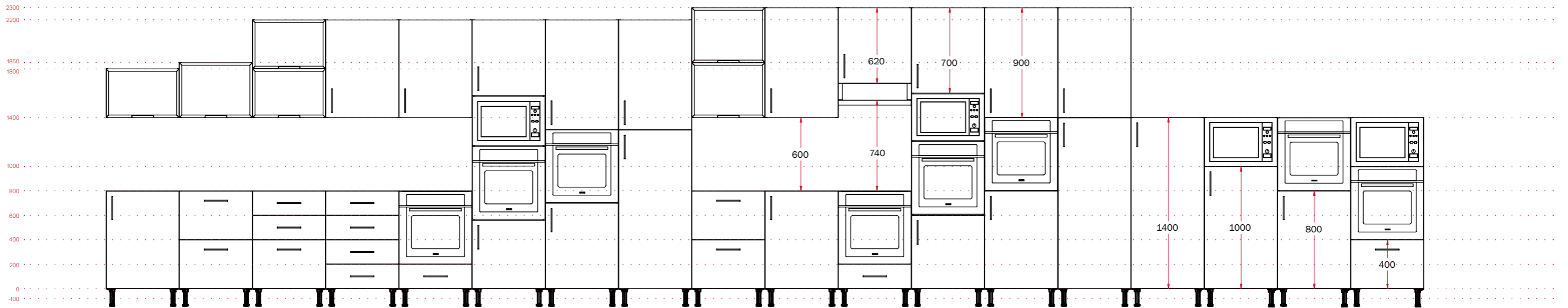

Modules Pro

High

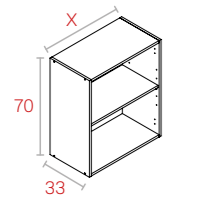

High Module H70

X	30	35	40	45	50
	60	70	80	90	100

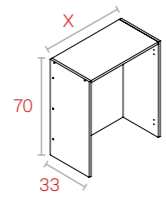

Dish drainer module H70

X	60	80	90
---	----	----	----

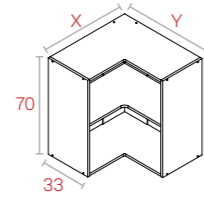

"L" Corner Module H70

X	Y
63 x 63	
64 x 65	

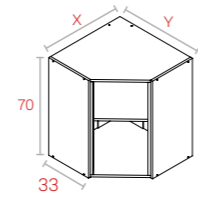

Corner Module with Chamfered Corner H70

X	Y
63 x 63	
59 x 60	

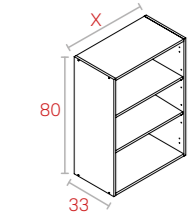

High Module H80

X	30	35	40	45	50
	60	70	80	90	100

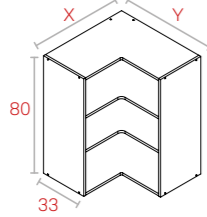

"L" Corner Module H80

X	Y
63 x 63	
64 x 65	

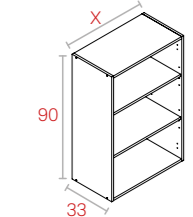

High Module H90

X	30	35	40	45	50
	60	70	80	90	100

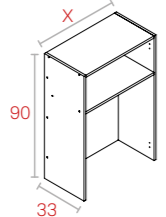

Dish drainer module H90

X	60	80	90
---	----	----	----

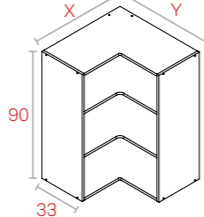

"L" Corner Module H90

X	Y
63 x 63	
64 x 65	

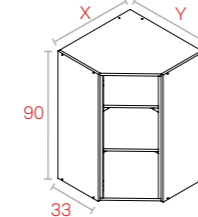

Corner Module with Chamfered Corner H90

X	Y
63 x 63	
59 x 60	

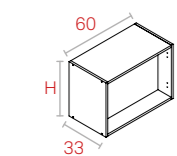

Hood Cover Module

H	42	62
---	----	----

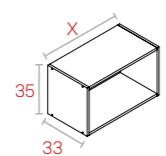

Horizontal Module H35

X	60	80	90
---	----	----	----

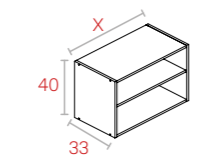

Horizontal Module H40

X	60	80	90
---	----	----	----

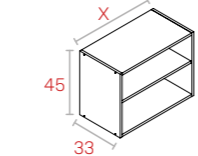

Horizontal Module H45

X	60	80	90
---	----	----	----

Columns

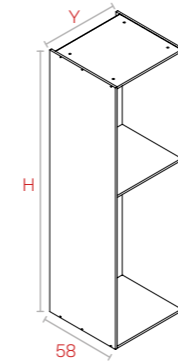

Pantry Column

HxY	200x40	200x60
	220x40	220x60
	230x40	230x60

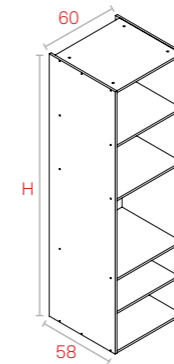

Oven+Microwave column

H	200	220	230
---	-----	-----	-----

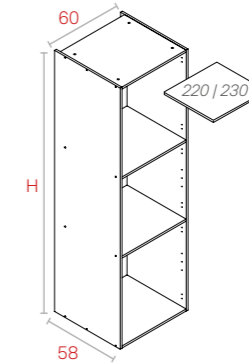

Oven / Pantry Column

H	200	220	230
---	-----	-----	-----

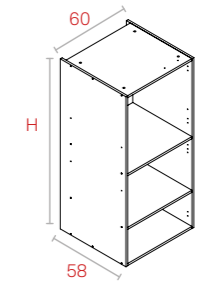

Semi-column

H	130	140
---	-----	-----

Low

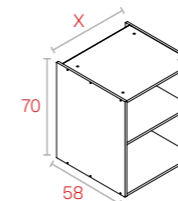

Low Module B70

X	15	30	35	40	45	50
	60	70	80	90	100	120

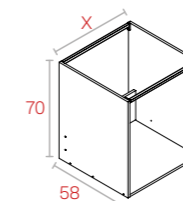

Sink Module B70

X	45	50	60	70
	80	90	100	120

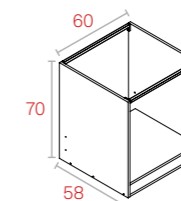

Oven Module B70

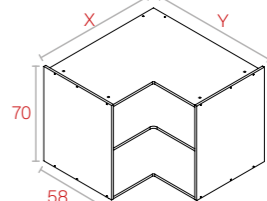

"L" Corner Module B70

X	Y
93 x 93	
94 x 95	
108 x 108	

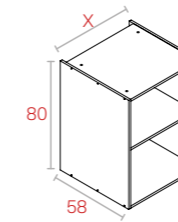

Low Module B80

X	15	30	35	40	45	50
	60	70	80	90	100	120

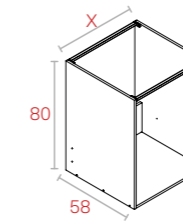

Sink Module B80

X	45	50	60	70
	80	90	100	120

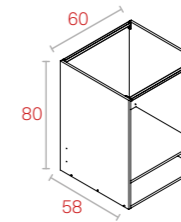

Oven Module B80

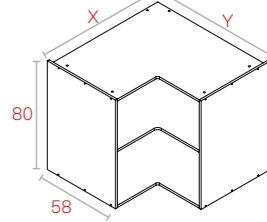

"L" Corner Module B80

X	Y
93 x 93	
94 x 95	
108 x 108	

Accessoires

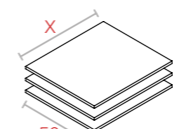

Pack including Mobile shelves

X	36,7 (40)	56,7 (60)
---	-----------	-----------

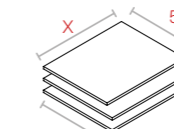

Pack including Base+Lid+Fixed back

X	41,8 (45)	46,8 (50)
---	-----------	-----------

Availability of:

- Panels with and without groove
- Packs of machined side pieces
- Board for rear panels
- Other module sizes

Consult our commercial network.

Modules

Max

Professional kitchen module series created to develop projects where the quality of materials and design are vital.

Main features

Baseboard

Fimoplast Moisture Resistant 19 mm, with double-sided design.

Edge

Front panels in 1 mm ABS, others in 0.4 mm ABS

Back

Fimoplast standard 6 mm with double-sided design

Assembly

Allen assembly screw + Wooden peg

Packaging

Shrink wrap with MR identification

Technical specifications

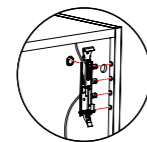

Machining for concealed hanger
*Hangers not included

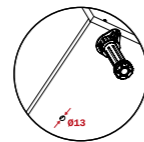

Suitable for 40/50 mm fin
* Legs not included

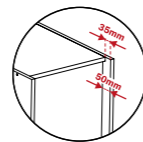

Rear recess with space for sockets, pipes and ventilation

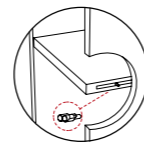

Anti-roll shelves with concealed fittings

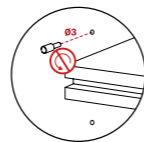

Discrete Holes



More information

Manufactured with a 19 mm Fimoplast Moisture Resistant baseboard for a more robust module that offers excellent performance in humid environments. This board quality offers an advantage in terms of hardware anchorage and flex, compared to other boards.

The melamine coating allows for easy cleaning, is scratch resistant and has an antibacterial surface.

The edges are banded with ABS.



Moisture resistant



E05



Anti-bacterial



Good fastener performance



Machined



Bending resistance

Designs



Blanco Polar
Soft III



Gris Gu
Soft III

Max range module diagram

Module diagram with low H80

Extra space and ergonomics

The development of the furniture has been carried out with the aim of achieving better ergonomics, increased storage capacity, a very careful design with micro-drilled holes and shelves with invisible fixings.

The two design alternatives offered respond to clear + market trends and fit in perfectly with the best-selling kitchen fittings and fronts.

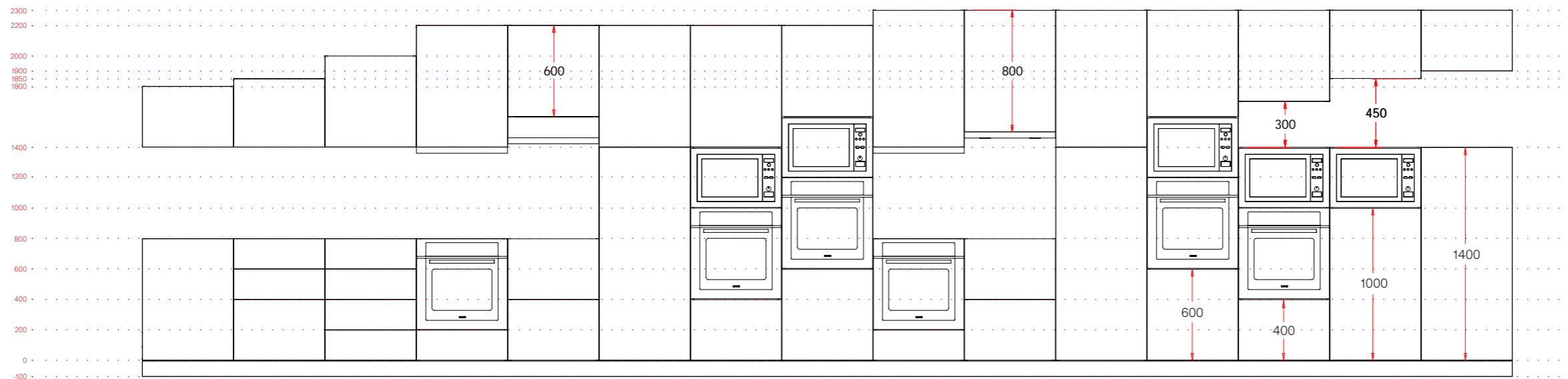

Modules Max

High

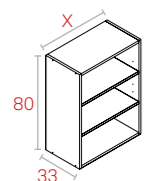

Upper Module H80

X	30	35	40	45	50
	60	70	80	90	100

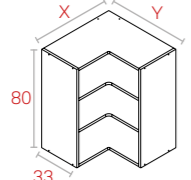

"L" Corner Module H80

X	Y
63 x 63	
64 x 65	

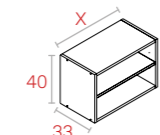

Horizontal Module H40

X	60	80	90
---	----	----	----

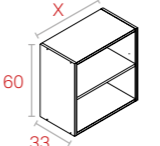

Upper Module H60

X	60	80	90
---	----	----	----

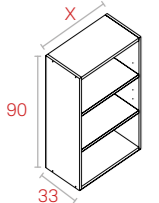

Upper Module H90

X	30	35	40	45	50
	60	70	80	90	100

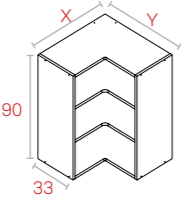

"L" Corner Module H90

X	Y
63 x 63	
64 x 65	

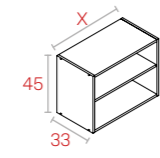

Horizontal Module H45

X	60	80	90
---	----	----	----

Low

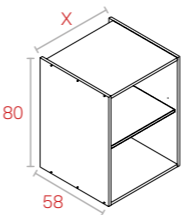

Lower Module B80

X	15	30	35	40	45	50
	60	70	80	90	100	120

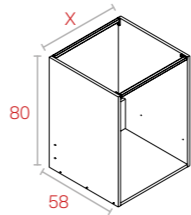

Sink Module B80

X	45	50	60	70
	80	90	100	120

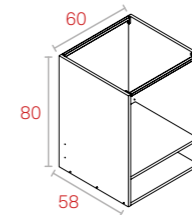

Oven Module B80

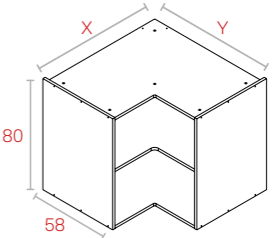

"L" Corner Module B80

X	Y
93 x 93	
94 x 95	

Columns

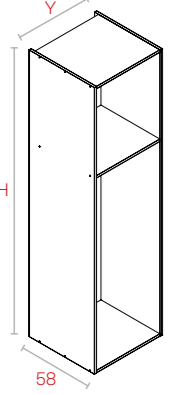

Pantry Column

HxY	220X40	230X40
	220X60	230X60

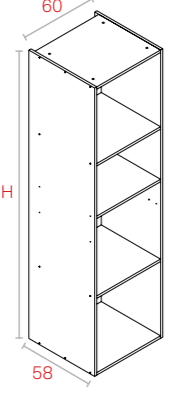

Oven+Microwave column

H	220	230
---	-----	-----

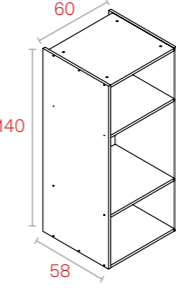

Semi-column

Accessoires

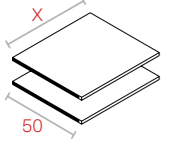

Pack including Slotted mobile shelves

X	36,2 (40)
	56,2 (60)

Availability of:

- Panels with and without groove
- Packs of machined side pieces
- Board for rear panels
- Other module sizes

Consult our commercial network

Worktops

Fintop+

Kitchen worktop developed as a horizontal solution to meet the demands of everyday use. It has antibacterial protection and features a decorative design on the top, back side and insulating back edge. The technology used in the manufacture of the surface allows the worktop to comply with the tests of the kitchen standard UNE 56875.

Main features



Baseboard

SuperPan® Decor MR 30 mm - 42 kg/ud
SuperPan® Decor MR38 mm - 53 kg/ud

Dimensions

3660x630 mm

Front edge

Double, postformed: 3 mm radius

Other features

Generic back edge
Sealing gasket

Coated counterface
Protected with film

Comments

The diverse range of colours and options also allows this product to be used for other applications such as: work tables, catering furniture, etc. Availability of:

- Edge banding of each design to finish off the sides.
- Aluminium profiles for straight and corner joints.
- Worktop connection fittings
- Possibility of manufacturing counters

Profiles

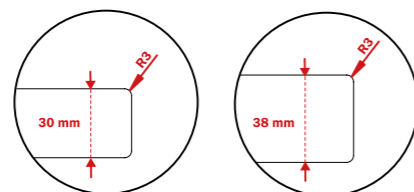

More information

Range of kitchen worktops developed based on our exclusive SuperPan®, MR which gives the product high impact resistance, superior cutting quality for perfect joints and greater resistance to humid environments.

It is available in two thicknesses, 30 mm and 38 mm, providing a feeling of firmness and robustness. The entire Fintop+ range is supplied postformed on the front, giving it an image of continuity and avoiding joints that accumulate dirt.

Thanks to the technology used in the melamine coating, we can offer products with designs and textures similar to natural materials that are suitable for contact with food, easy to clean, resistant and equipped with an antibacterial treatment.

We have made a selection of decorations that incorporate exclusive designs for all tastes. Most of the items are from our Duo range, which greatly facilitates combinations with fronts and finishes, as well as using the same tones in projects with shared spaces such as kitchens that open out onto a living room.









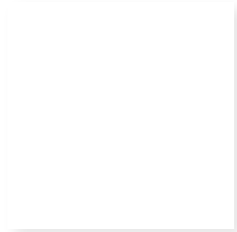
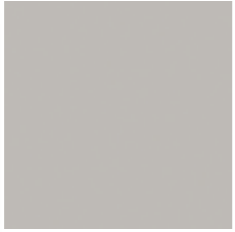
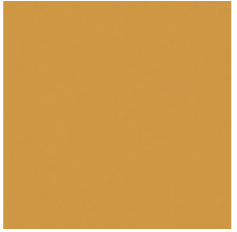

We also manufacture counters on request.

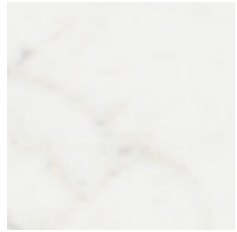
To ensure the longest possible service life, Fintop+ worktops come with a coated counterface and edged back. We also incorporate a sealing gasket on the front to prevent water dripping into the furniture.



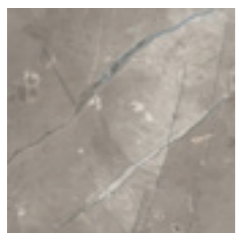
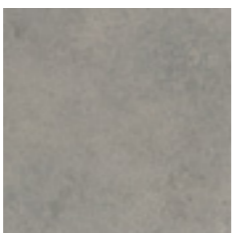

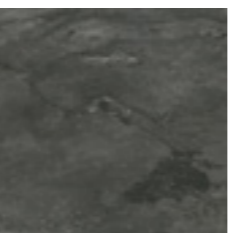
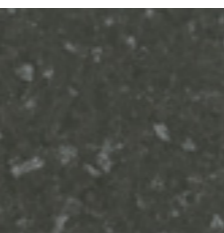
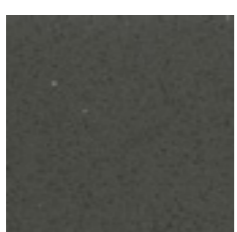
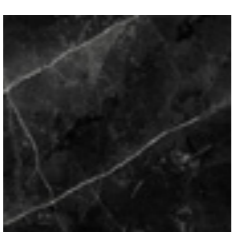
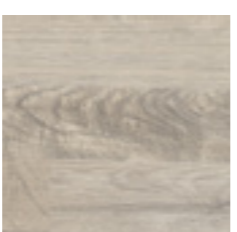

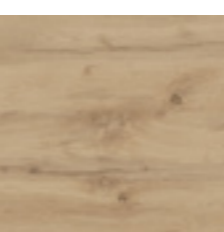
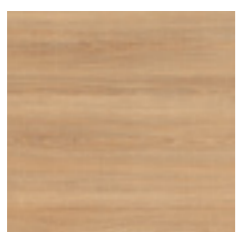
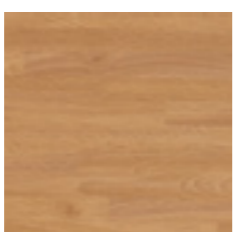
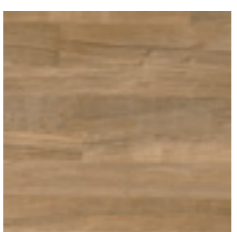

Designs

30 mm

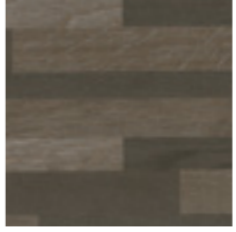
				
030 Blanco Super Balm	206 Gris 004 Balm	0AU Amarillo Pompeya Balm	7AT Verde Oliva Balm	8AQ Aluminio Cava Balm
				
72Y Marmol Blanco Balm	47S Granito Gala Moa	02E Claro Trento Moa	44V Luna Nueva Moa	1AR Pietra Iseo Moa
				
2AE Marmol Atenea Balm	06F Cemento Moa	98G Textil Cuero Moa	94D Pizarra Moa	46S Granito Labrador Moa
				
97D Negro Trento Moa	1AT Marmol Hades Balm	21Y Roble Olbia Antiq	8AE Hygge Pine Antiq	80Y Roble Hércules Antiq
				
41G Roble Hera Antiq	024 Haya Laminado Antiq	43S Roble Block Antiq		

30 mm

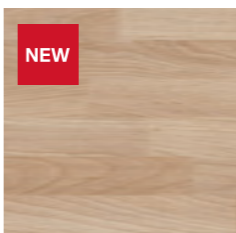
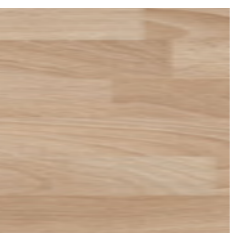
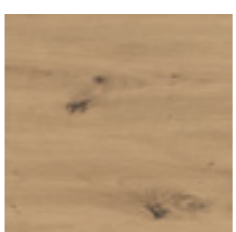
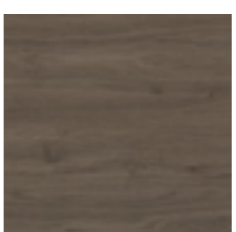
		
33Y Roble Winchester Antiq	06Y Wild Wood Antiq	55F Albura Block Antiq
	 NEW	
9AS Creta Marfil Moa	06F Cemento Moa	0AR Lava Stone Moa
	 NEW	
3AT Bohemian Blanco Antiq	515B Haya Colmar Antiq	9AR Hickory Frida Antiq
		
6AS Roble Amazona Antiq	4AE Roble Eternity Antiq	

38 mm



Finishes

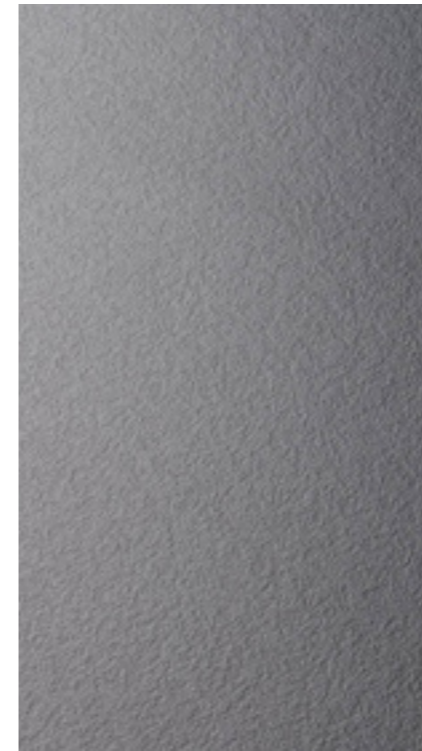

Moa

A beaded stone-effect texture, matt and soft to the touch. It has a homogeneous structure that blends perfectly with various kinds of decors: cements, limestone, granite, terrazzo, rusty, etc.

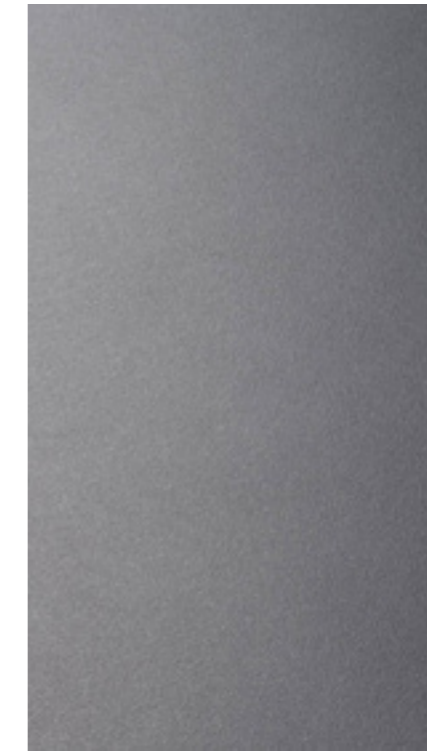

Balm

Super-matt texture and a pleasant warm touch that resists fingerprint stains effectively. Balm is a very versatile finish, which works perfectly with single colours, metallic textures or marble without dulling the intensity or colours of the décor.



Antiq

Very deep texture with rustic brushed wood effect. It has a touch of warmth and a matt appearance. Its homogeneous structure is very versatile and can be combined with smooth woods as well as with rustic and planked woods.

Worktops

Fintop Xtrim NEW

A range of worktops manufactured using an exclusive HDF board and especially developed for horizontal application, thanks to our innovation, we achieve excellent performance and high performance and excellent hardness, which allows Xtrim worktops to be used intensively.

Main features

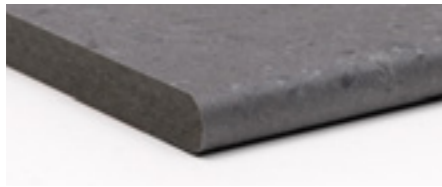

Core board

High performance HDF 13 mm - 27 kg/unit

Size

3660 x 630 mm

Front side edging

Double postformed: 5 mm radius

Other features

Overlaid underside
Protective film

Comments

Manufactured using an exclusive HDF board and especially developed for horizontal application, thanks to our innovation, we achieve excellent performance and high performance and excellent hardness, which allows Xtrim worktops to be used intensively. It complies with the tests of the kitchen standard UNE 56875.

Also available

- Edging rolls
- Connecting bolts
- Possibility of manufacturing counters



Profiles

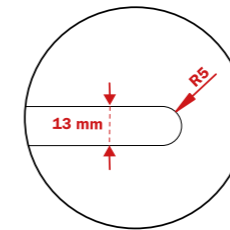

Moisture resistant



E05



Anti-bacterial



Cutting quality



Impact resistance



Easy cleaning



Postformed worktop



High density



CARB2

Designs



72Y Mármol Blanco
Balm



9AS Creta Marfil
Moa

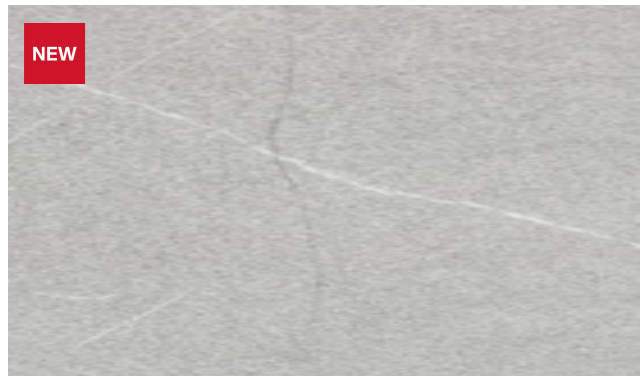

583B Pietra Alba
Moa



267B Gravity Marengo
Moa

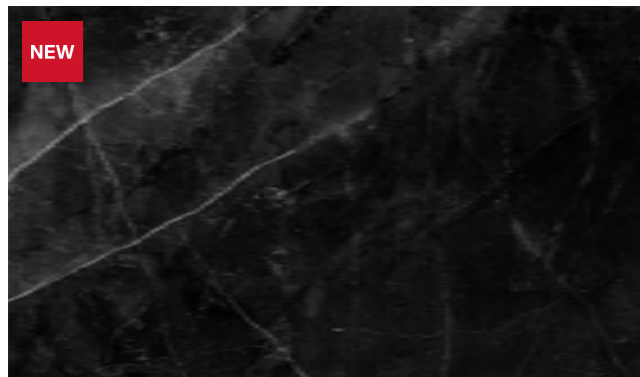

1AT Mármol Hades
Balm

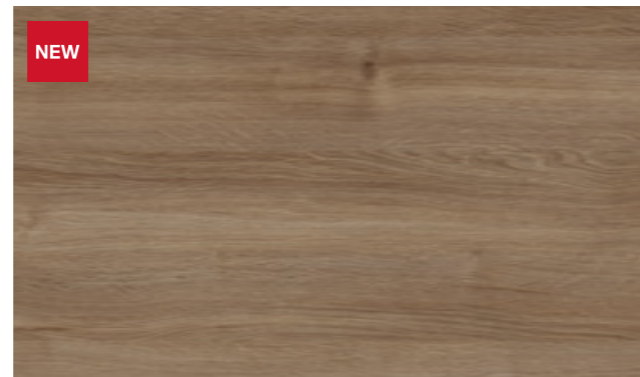

274B Roble Romance
Antiq



251B Lecer
Antiq



6AS Roble Amazona
Antiq



Finishes

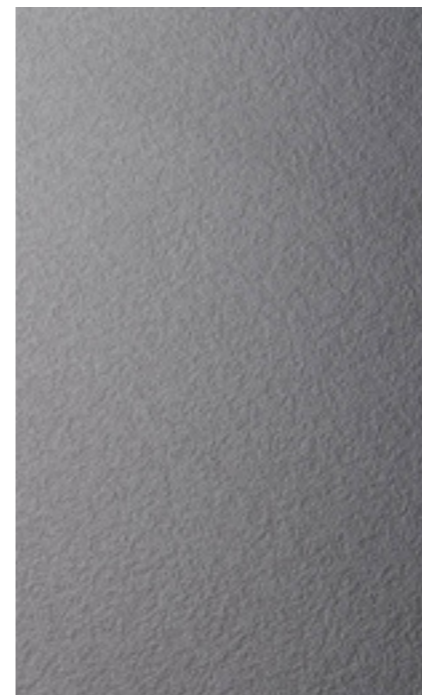

Moa



Balm



Antiq

Worktops

Fintop SQ

Main features

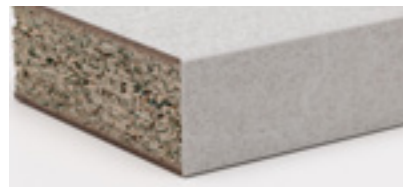

A range of straight-edged worktops that combine an ultra-resistant SuperPan® MR stand with a range of decorative elements that add a modern look to the kitchen design. Easy to clean, resistant to moisture and with antibacterial surface, has edges and splashbacks to match.

Baseboard

SuperPan® Decor MR 38 mm - 53 kg/ud

Dimensions

3660 x 630 mm

Edge

ABS edge of 1 mm, guaranteeing an elegant and contemporary look in every kitchen. They have a coated back side and a generic edge on the back.

Comments

The combination of designs and textures from the range on the ultra-resistant SuperPan® MR baseboard makes our Fintop SQ worktop an ideal solution for any of your projects. The ABS edge and PUR gluing, which provide greater heat and wear resistance than other materials, offer maximum guarantees for daily use. In addition, the technology used in the manufacturing of the surface allows the worktop to meet the tests of the UNE 56875 kitchen standard.

Availability of

- Splashbacks available
- Edges in rolls to finish the projects to measure
- Edge effect test available in some designs
- Hardware for joining worktops
- Possibility of manufacturing counters



More information

SuperPan® is a board composed of wood fiber faces and a core of agglomerated wood particles. It is an innovative solution patented by Finsa, which we exclusively manufacture through a continuous pressing process. This technique gives it great performance for different industrial technologies, as it combines the main advantages of MDF and particle boards. The MDF faces allow worktops made with SuperPan® to have greater impact resistance.

For our Fintop SQ range, we use the MR quality to provide maximum guarantees in humid environments.



Moisture resistant



E05



Anti-bacterial



Cutting quality



Impact resistance



Easy cleaning



ABS edge

Designs

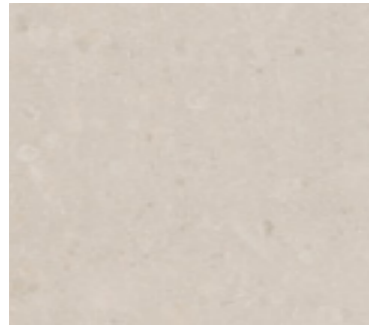

271B Gravity Hueso
Moa



269B Gravity Arena
Moa



268B Gravity Niebla
Moa

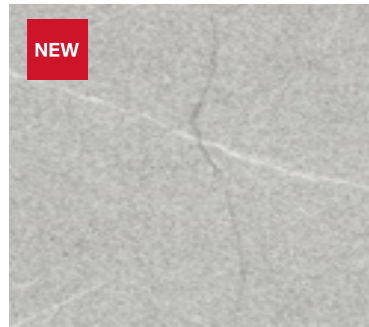

583B Pietra Alba
Moa



267B Gravity Marengo
Moa

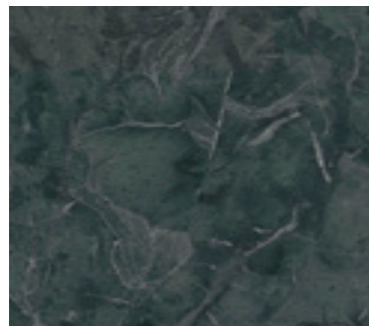

472B Mármol Flora
Balm

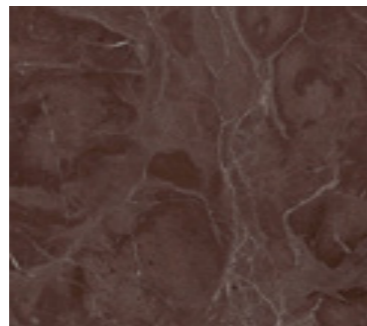

473B Mármol Artemisa
Balm

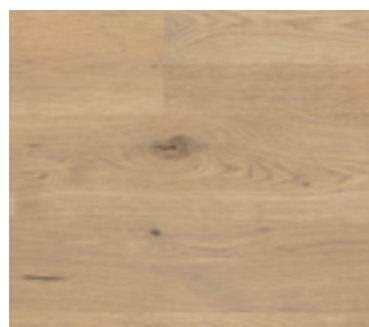

264B Navia Natural
Antiq

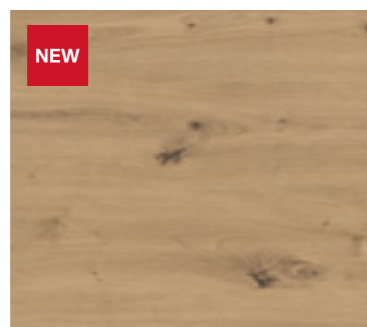

6AS Roble Amazona
Antiq

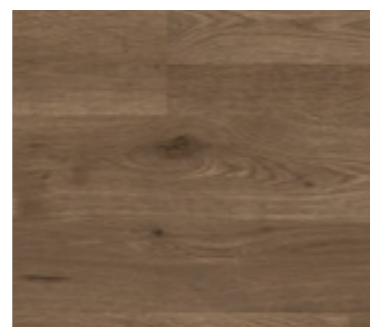

265B Navia Brown
Antiq



Finishes

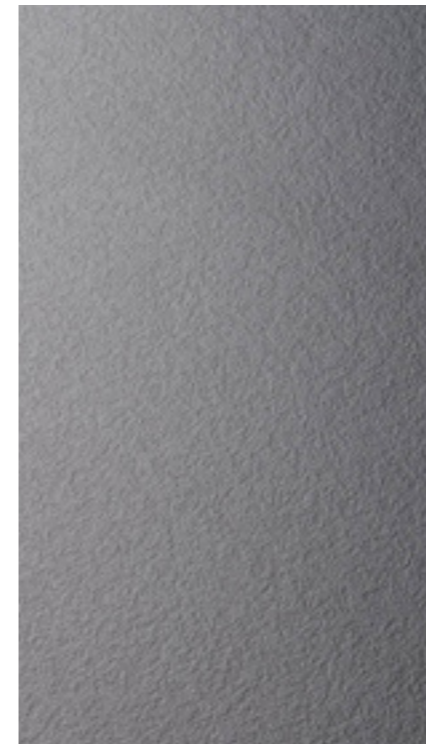

Moa

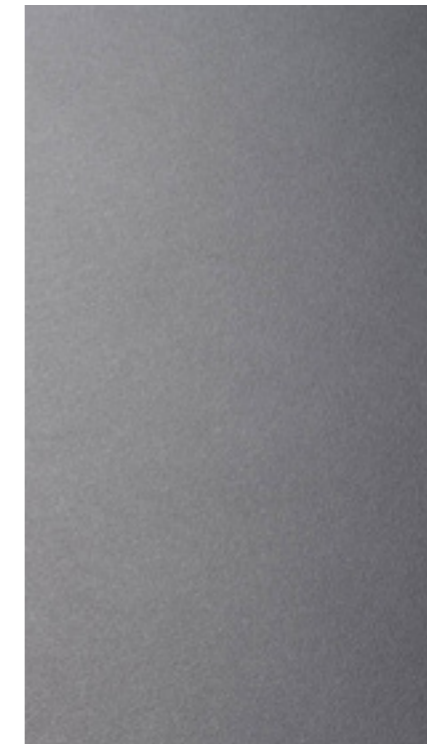

Balm



Antiq

Fronts

Finporta

Postformed on two sides, for configuration of kitchen furniture fronts. These allow you to produce all kinds of combinations of doors, drawers, drawer units, etc.

Main features

Baseboard

SuperPan® Decor 19 mm, with two-sided design and finish

Length

2850 mm (useful size: 2800 mm)

Width

From 148 to 898 mm

Front edge

Single, postformed: 3 mm radius

Comments

Their most common application is kitchen fronts, although they are also used as doors for wardrobes, office furniture, home furniture, contract furniture, etc.

- Counterpoint shelf
 - Finished doors on request.
- Consult our commercial network.

Profiles

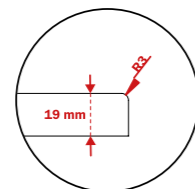

More information

SuperPan® is a high-performance material that ensures optimum surface resistance, excellent fastening of fittings and a perfect cut finish.



E05



Anti-bacterial



Cutting quality



Fastener performance



Machined

Designs

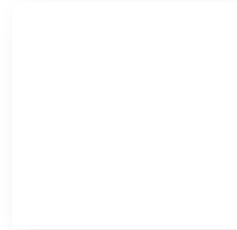

030 Blanco Super
Soft III

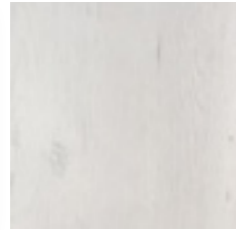

91Y Roble Dafne
Atlas



98V Roble Aurora
Atlas



84V Roble Denver
Atlas



97V Roble Colorado
Atlas

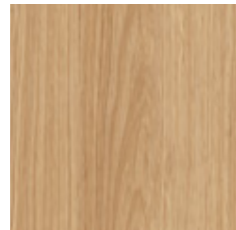

41G Roble Hera
Atlas



80Y Roble Hércules
Atlas

Finishes

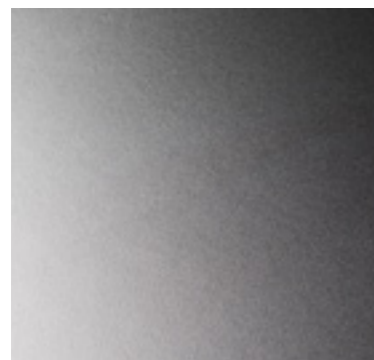

Soft III
Soft texture and matte look.

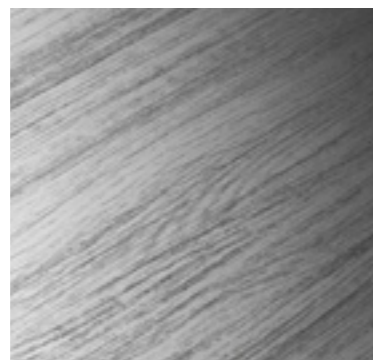

Atlas
Wood texture and rustic character.



Finsa

All rights reserved. No part of this catalogue may be reproduced in any form without the prior written permission of Finsa, in writing from Finsa. The designs presented in this catalogue are a reproduction. Please request a physical sample or consult our sales network before making a decision.

finsa.com

